

# ECO-SEAL™ SERIES 4300 ED

## Dimensions

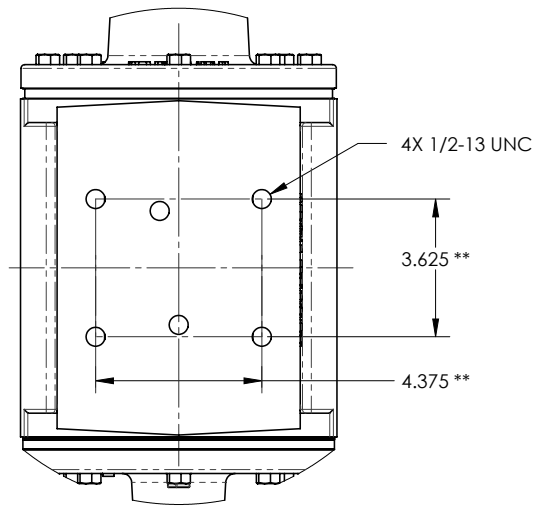

BOTTOM VIEW

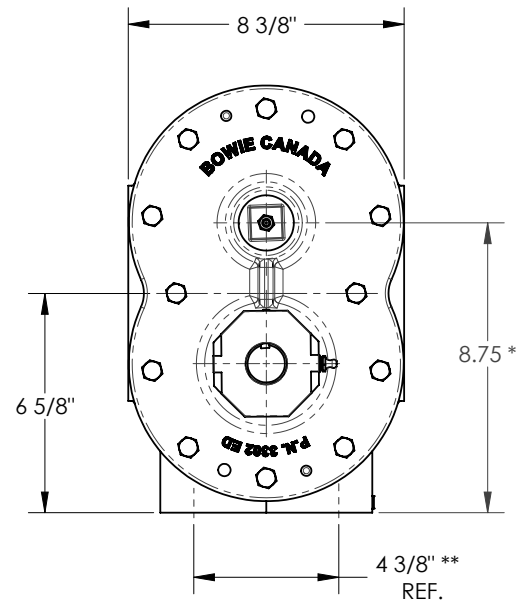
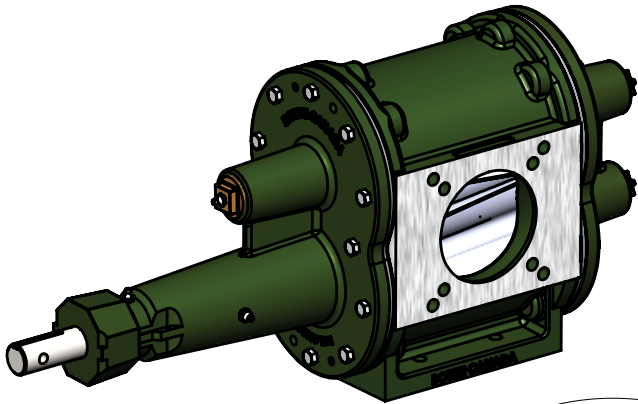
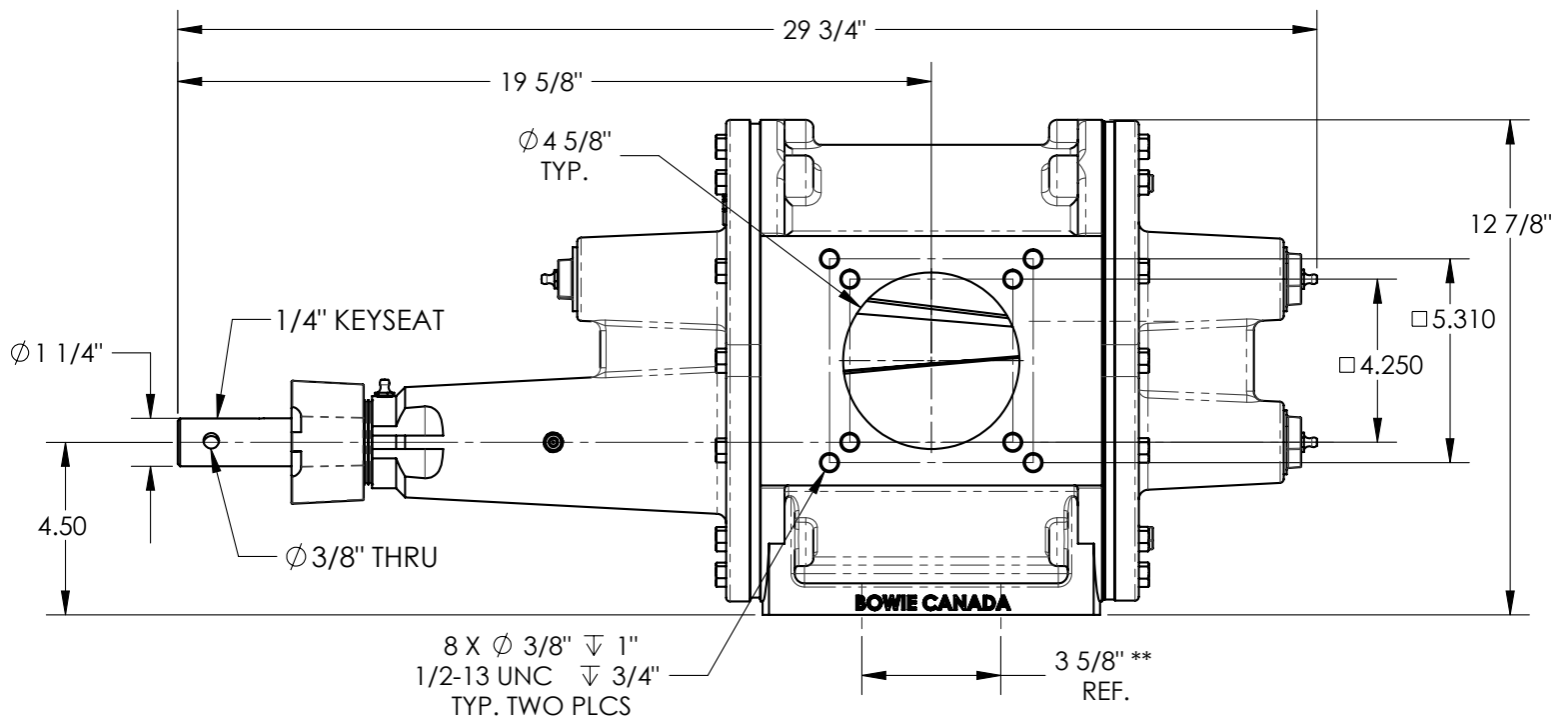

\* THE DISTANCE TO THE CENTERLINE OF DRIVE SHAFT FOR "DRIVE ON TOP" APPLICATION; "DRIVE ON TOP" APPLICATION IS OPTIONAL;

\*\* BASE BOLT PATTERN 4 x 1/2-13UNC;

"LEFT" & "RIGHT" configurations are shown;  
Dimensions are symmetrical;

